



GENERAL INFORMATION

The **Source Four LED Series 2** is the evolution of LED lighting. While it may look the same on the outside, the Series 2 offers even more of what makes the Source Four LED the best LED profile available. With optimised arrays and fine-tuned electronics, the Series 2 offers a combination of colour and output that cannot be matched.

Source Four LED Series 2 Lustr® luminaires are based on the x7 Color System™, utilising seven colours including high-output lime to achieve true, usable broad-spectrum colour with a depth and feel beyond any RGB fixture.

Source Four LED Series 2 Daylight HD and Tungsten HD arrays are designed for broadcast lighting, offering flicker-free operation and high-definition lighting. With a new mix of LED emitters, the luminaires' output is significantly brighter than the original Source Four LED white-light arrays. In addition, they offer colour tint control, so they can be tweaked to perfectly illuminate individual skin tones.

The Daylight HD array produces variable-cool white (Key performance from 4000 to 6500K) light that imitates natural daylight.

The Tungsten HD array matches conventional tungsten lighting, with adjustable warm-white (Key performance from 2700 to 4500K) light.

Series 2 light engines work with all Source Four lens tubes to deliver a high-quality, controllable beam of LED light. For the best results, it is highly recommended that EDLT versions are used. We also offer a special LED-only version of the 50° lens tube, asymmetric CYC Adapter and Fresnel Adapter (Further information - see Datasheets).

ORDERING INFORMATION

Source Four LED Series 2 Light Engine with Shutter Barrel

(For use with fixed-field lens tubes only)

PART NO.	DESCRIPTION
7461A1251	Source Four LED Series 2 Lustr w/ shutter barrel, Black
7461A1261	Source Four LED Series 2 Tungsten HD w/ shutter Barrel, black
7461A1271	Source Four LED Series 2 Daylight HD w/ shutter barrel, Black

Source Four LED Series 2 Light Engine - Body Only

(For use with zoom lens tubes, Cyc adapters and for retrofit of existing tungsten fixtures)

PART NO.	DESCRIPTION
7461A1250	Source Four LED Series 2 Lustr – Body only, Black
7461A1260	Source Four LED Series 2 Tungsten HD – Body only, Black
7461A1270	Source Four LED Series 2 Daylight HD – Body only, Black

Colour options: -1 = White, -5 = Silver Grey/Custom Colour. Fixture ships with 1.8m PowerCON to bare ends power input lead and Soft Focus Diffuser in gobo holder.

Please note: Lens Tubes, Fresnel and Cyc Adapter to be ordered separately.

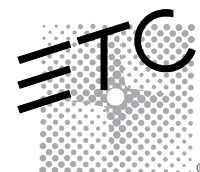

SPECIFICATIONS

GENERAL

- 60 LED colour mixing fixture
- IP20-rated for indoor dry location use
- CE compliant
- Power and DMX in/thru connections for easy setup
- User-friendly control interface with multiple modes and fixture settings

PHYSICAL

- Rugged die-cast all-metal housing
- Available in black, white and silver grey. Custom colours available on request
- Positive-locking double-clutch yoke
- Slot for B-size glass, stainless steel or film gobo patterns and Soft Focus Diffuser media
- Wide accessory slot with sliding cover for motorised effect devices, A-size gobos or optional drop-in iris

ELECTRICAL

- 100VAC to 240VAC 50/60 Hz universal power input
- Neutrik power in and thru connections
- Up to eight Lustr or seven Daylight HD/Tungsten HD luminaires (15A max) may be linked via power thru connector when used with Sensor or Unison Relay Modules.
 - Consult breaker-trip curves when used with other equipment. Requires power from a non-dim source
- Inrush current 230V: 107A (For about one half-cycle)

LED*

- 20,000-hour LED life (20,000 hours to 70% intensity)
- 60 Luxeon® Rebel LED emitters

*See additional LED notes on page three

COLOUR

- Exclusive x7 Color System seven-colour LED array (Lustr)
- Selection from the x7 Color System to provide high quality, variable-white light versions:
 - Tungsten HD (Best performance 2700K-4000K)
 - Daylight HD (Best performance 4000K-6500K)
- Beautifully illuminates skin tones and other objects for natural appearance and high colour rendering
- Broad-spectrum colour interacts seamlessly with conventional sources
- Exclusive optional red-shift option emulates tungsten dimming performance

OPTICAL

- Use the included Soft Focus Diffuser for creating washes or soft light distribution
- Best performance using ETC's EDLT lens tubes
- Can use all ETC Source Four interchangeable lens tubes: 5°, 10°, 14°, 19°, 26°, 36°, 50°, 70°, and 90° field angles, as well as 19°, 26°, 36°, and 50° EDLT lens tubes
- For better performance, use the LED-specific 50° lens tube

CONTROL

- DMX512 in and thru via five-pin XLR connectors
- Multiple control options, including RGB, strobe, and console-free Master/Slave mode
- See DMX Control Table for additional information
- 15-bit virtual dimming engine provides smooth, high-quality theatrical fades and minimises colour shift during dimming
- RDM functionality for address and setting changes

SPECIFICATIONS

THERMAL

- Ambient operating temperature of 0° to 40°C
- Active electronic thermal management for droop-free operation
- Quiet fan cooling
- Fixture is designed for continuous operation up to 40°C ambient temperature and requires free flow of air around fixture housing

ADDITIONAL ORDERING INFORMATION

Power cable options

Note: Power thru jumpers connect to fixture's output (thru) connector to provide link to successive fixtures

PART NO.	DESCRIPTION
7410B7013	1.8m PowerCon™ to bare-end power input cable (Spare)
7410K1101	1m PowerCon™ to bare end power thru cable 3x1mm ²
7410K1102	1m PowerCon™ to PowerCon™ fixture to fixture jumper cable 3x1mm ²
7410K1103	2m PowerCon™ to PowerCon™ fixture to fixture jumper cable 3x1mm ²
7410K1104	5m PowerCon™ to PowerCon™ fixture to fixture jumper cable 3x1mm ²
7410K1105	1m fixture to fixture twin jumper cable with both power and DMX connectors
7410K1106	2m fixture to fixture twin jumper cable with both power and DMX connectors
7410K1107	5m fixture to fixture twin jumper cable with both power and DMX connectors

Diffusers

PART NO.	DESCRIPTION
7460A4019	Source Four LED—Soft Focus Diffuser (spare)
7460K1006	Source Four LED—Soft Focus Diffuser permanent installation kit (magnets + diffuser)
7460K1001	Source Four LED—Smooth Wash Diffuser media for use in 159mm Colour Frames (19°-26°-36° and 50° Lens Tubes)
7460K1002	Source Four LED—Smooth Wash Diffuser media for use in 190mm Colour Frames (14°-50° LED-70° and 90° Lens Tubes)
7460K1003	Source Four LED—Smooth Wash Diffuser media for use in 305mm Colour Frame (10° lens tube)
7460K1004	Source Four LED—Smooth Wash Diffuser media for use in 356mm Colour Frame (5° lens tube)

The Soft Focus Diffuser delivers beautiful homogenised light when not in sharp focus. Also, use in combination with gobo patterns for dappled and soft-edge projections

The Smooth Wash Diffuser is used when extra-smooth blending of multiple Source Four LED fixtures is required. The smooth wash diffuser is placed into the gel-frame slot of the lens tube.

FIXTURE COMPARISON - LUSTR

- The data below was measured on a Source Four LED Series 2 Lustr and a Source Four LED Lustr+, both in Regulated mode. Gel colours shown are standard selections from the Rosco Laboratories Inc. and Lee Filters catalogs.

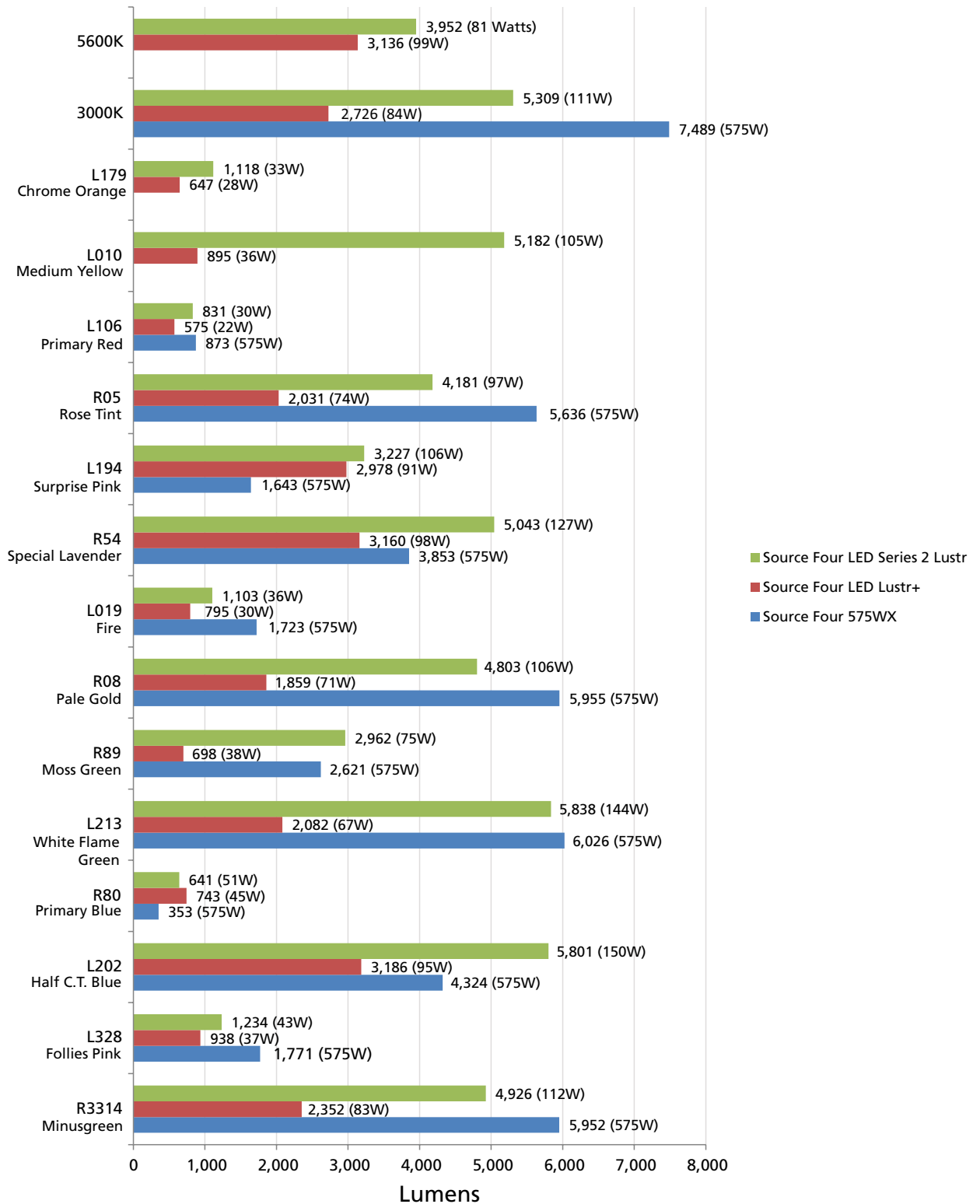

FIXTURE COMPARISON - DAYLIGHT HD AND TUNGSTEN HD

- The data below was measured on a Source Four LED Series 2 Daylight HD and Tungsten HD against a Source Four LED Series 1 Studio HD, Studio Daylight and Studio Tungsten. All in Regulated mode.

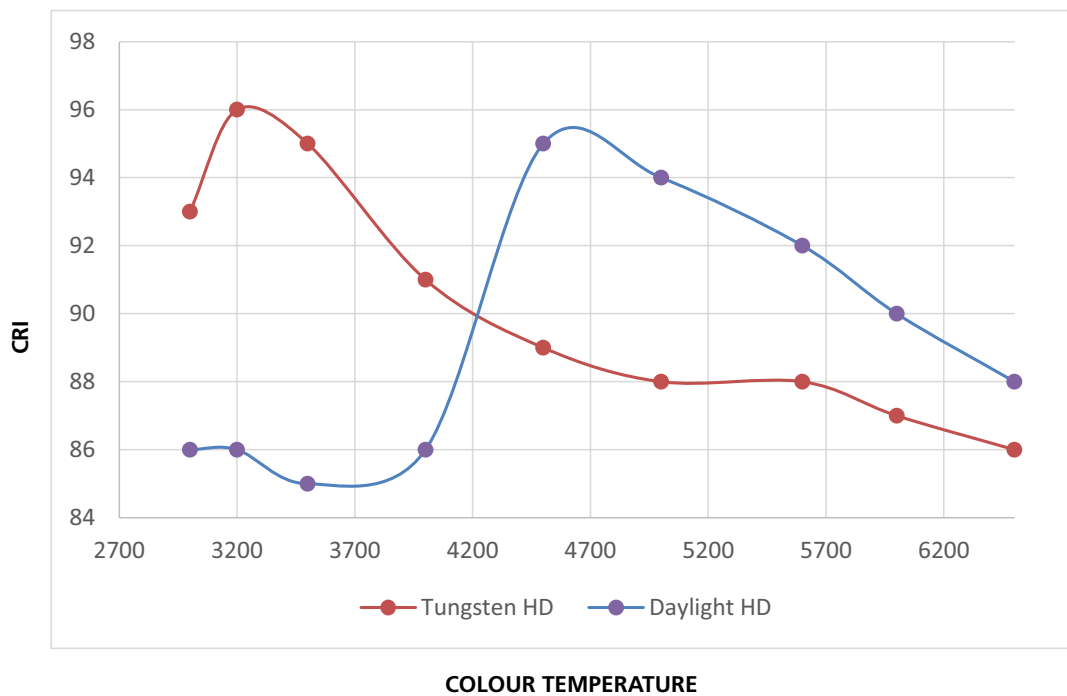
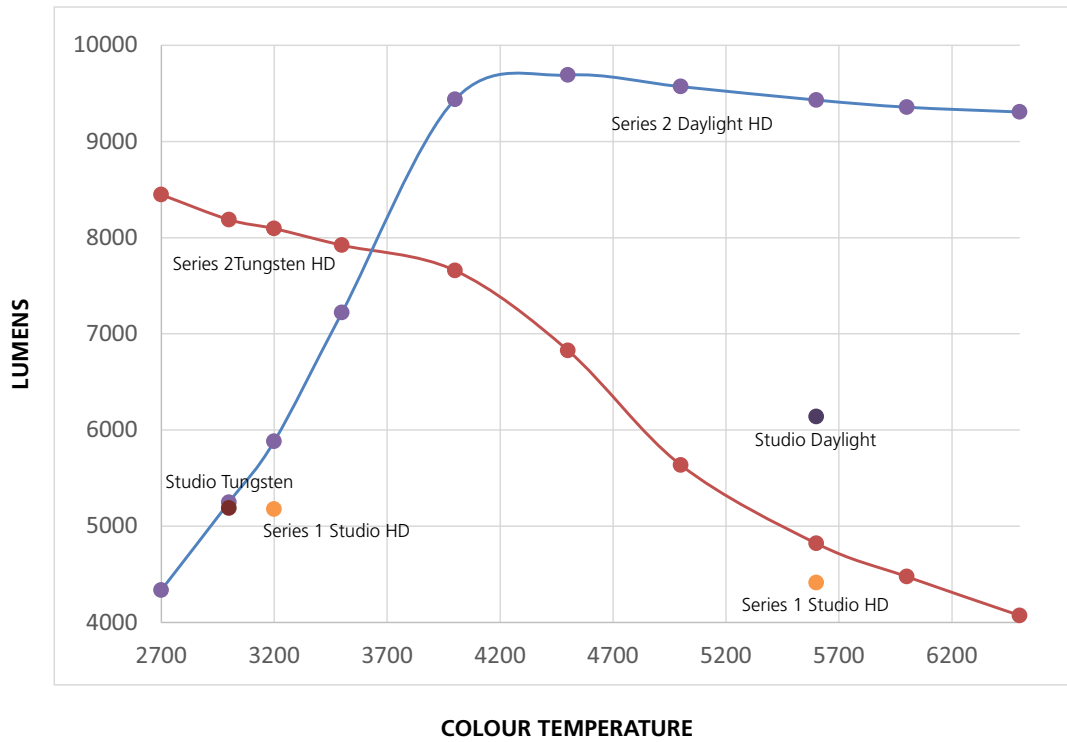

RECOMMENDED LENSING OPTIONS

(Lense Tubes sold separately)

Fixed Field Lens Tubes

PART NO.	DESCRIPTION
7460A2008	LED specific 50° EDLT Lens Tube, Black
7060A2048	36° EDLT Lens Tube, Black
7060A2047	26° EDLT Lens Tube, Black
7060A2046	19° EDLT Lens Tube, Black
7060A2052-K	90° Lens Tube, Black
7060A2051-K	70° Lens Tube, Black
7060A2050-K	14° Lens Tube, Black
7060A2001-K	10° Lens Tube, Black
7060A2000-K	5° Lens Tube, Black

Zoom Lens Tubes

Use with light-engine body models.

PART NO.	DESCRIPTION
7060A2030-K	15°-30° Zoom Lens Tube, Black
7060A2032-K	25°-50° Zoom Lens Tube, Black

Source Four LED Cyc Adapter

Use with light-engine body models.

PART NO.	DESCRIPTION
7060A2011	Source Four LED CYC Adapter, Black
7460A2014	Source Four LED CYC Barndoor (horizontal leaves)
PSF1118	Source Four LED CYC Floor Base

Source Four LED Fresnel Adapter

Use with light-engine body models.

PART NO.	DESCRIPTION
7060A2016	Source Four LED Fresnel Adapter, Black
PSF1101	Source Four Fresnel Barndoor, Black

Power Consumption at Full Capacity

MODEL	VOLTAGE (V)	CURRENT (A)	MAX POWER (W)
Source Four LED Series 2 Lustr	230	0.42	171
Source Four LED Series 2 Tungsten HD	230	0.53	208
Source Four LED Series 2 Daylight HD	230	0.6	246

ADDITIONAL ORDERING INFORMATION

Accessories

PART NO.	DESCRIPTION
7060A1012	Source Four Drop-In Iris
7060A1075	Size B Metal Gobo Holder
7060A1075-1	Size B Glass Gobo Holder
47060A1074	Size A Metal Gobo Holder (For use in Effects slot)
4060A1074-1	Size A Glass Gobo Holder (For use in Effects slot)

NOTES ABOUT LED LUMINAIRES

All LED sources experience some lessening of light output and some colour shift over time. LED output will vary with thermal conditions. Based on the LED manufacturer's B50 L70 specification, a Source Four LED Series 2 luminaire will achieve ~70% of its initial output after 20,000 hours of typical usage. In individual situations, LEDs will be used for different durations and at different levels. This can eventually lead to minor alterations in colour performance over time, necessitating slight adjustments to presets, cues or programs.

CRI AND CQS RATINGS

Source Four LED fixtures were evaluated for CRI and CQS performance using measured output spectrum and optimized mix solutions for a best spectral match to black body sources at 3200K and 5600K.

FIXTURE	CRI	CQS	Colour Fidelity	Duv
Source Four LED Series 2 Lustr Reg at 3200K	86	88	88	0
Source Four LED Series 2 Lustr Reg at 5600K	90	91	91	0
Source Four LED Series 2 Tungsten HD Reg at 3200K	94	91	91	0.002
Source Four LED Series 2 Daylight HD Reg at 5600K	91	89	88	0.002

All Source Four LED luminaire versions provide excellent colour rendering to the eye, particularly at higher colour temperature settings, such as 5600K. In most cases, the Duv is 0.000. A Duv rating of 0.000 indicates that the colour mix used is exactly on the black body line, with no green or magenta tint.

Source Four LED Series

CONTROL OPTIONS

User settings on Source Four LED Series 2 fixtures allow multiple operational modes and settings for either console operation via DMX protocol or stand-alone operation. The expanded LCD display provides easy navigation to all possible settings and options. Some of the setting options are:

- Multiple DMX choices ranging from a simple RGB profile – which effectively controls all seven LED colours via three channels – to nine-channel ‘direct’ colour and intensity control
- Multiple dimming curve options
- Preset colours and sequences for stand-alone (no console required) operation
- White point selection – white light and colour behavior based on a specific colour-temperature white light, i.e. 3200K, 5600K, etc.
- Loss of data behavior options – instant off, hold last look for two minutes, etc.
- Output modes – three output options that offer the user a choice between maximum output and maximum consistency

See the user manual for a complete explanation of all of the control settings and options for the Source Four LED Series 2.

Quick Setups

To assist in managing the numerous control and fixture behavior choices, five combinations of operational settings are available to quickly get started. These settings are specifically created for different applications and are easily accessible at the fixture display. Each setting can then be modified as required to take advantage of all of the possible control features.

Setting Title	Profile	Description	Typical Features*
General	Direct	Factory Default: For general-purpose use, including interior architectural applications	<ul style="list-style-type: none"> • Standard dimming curve • Regulated output for colour consistency
Stage	HSI Plus 7 Enabled	Theatrical lighting: Duplicates the colour and dimming behavior of tungsten stage lighting fixtures	<ul style="list-style-type: none"> • Incandescent dimming curve • Regulated output for colour consistency • 3200K white-point setting
XT Arch	HSI	Exterior architectural lighting: Provides a high degree of colour consistency in high ambient temperature environments	<ul style="list-style-type: none"> • Standard dimming curve • Protected output • 3200 white-point setting
High Impact	RGB	Event lighting: Enables quickest response, simple RGB control and strobe channel for maximum effect usage	<ul style="list-style-type: none"> • Quick dimming curve • Boost mode for maximum intensity • 5600K white-point setting
Studio	Studio	Studio factory default: Enables three-parameter control of white light (intensity, white point, and tint) via DMX from console or console-free from fixture display	<ul style="list-style-type: none"> • Linear dimming curve • Regulated output mode for color consistency

*See user manual for complete list of features for each Quick Setup

LUSTER CONTROL OPTIONS

DMX Input Channel Profiles

DMX Profile	DMX Channels	Channel Assignments	Notes
Direct	10	1 – Red 2 – Lime 3 – Amber 4 – Green 5 – Cyan 6 – Blue 7 – Indigo 8 – Intensity 9 – Strobe 10 – Fan Control	Direct control of each individual colour with a separate master-intensity channel. Colour calibration of LEDs is not active in this mode. This profile will produce additive colour crossfades.
HSI	6	1 – Hue (coarse) 2 – Hue (fine) 3 – Saturation 4 – Intensity 5 – Strobe 6 – Fan Control	High-resolution hue (two channels), saturation, and intensity control. HSI mode will produce colour crossfades around the colour space.
HSIC	7	1 – Hue (coarse) 2 – Hue (fine) 3 – Saturation 4 – Intensity 5 – Strobe 6 – Fan Control 7 – Colour Point (CCT)	High-resolution hue, saturation and intensity control as above, with the addition of a colour- point channel to adjust the colour temperature of the fixture in both white light and colour. Colour crossfade performance is the same as HSI.
RGB	6 (Ch. 4 not used)	1 – Red 2 – Green 3 – Blue 4 – n/a 5 – Strobe 6 – Fan Control	Effectively addresses all seven colours via three channels of control. RGB profile will produce additive colour crossfades.
Studio	6 (Ch. 4 not used)	1 – Intensity 2 – Colour Point (CCT) 3 – Tint 4 – n/a 5 – Strobe 6 – Fan Control	Controls fixture as a white light unit. If no DMX, (console input, for example), is present, the fixture can be adjusted for these three parameters on the user interface at the back of the unit.
Additional profile options			
Plus 7		Seven additional colour-control channels are available in RGB, HSI and HSIC input-profile settings. For example, HSI with ‘Plus 7’ enabled becomes a 15-channel profile:	
		1 – Hue (coarse) 2 – Hue (fine) 3 – Saturation 4 – Intensity 5 – Strobe 6 – Fan Control 7 – n/a 8 – Plus 7 Control on/off 9 – Red 10 – Lime 11 – Amber 12 – Green 13 – Cyan 14 – Blue 15 – Indigo	<p>The desired colour and intensity is achieved by using the HSI or RGB channels</p> <p>Placing channel seven at a value over 51% gives the fixture a 15-channel profile</p> <p>Channels 9-15 represent the native colours of the fixture and allow the operator to adjust individual colour channels to fine tune the colour output</p>
Strobe		Variable strobe control: 0% is no strobe. The fixture output will strobe more rapidly as the strobe channel value approaches 100%.	

Source Four LED Series

DAYLIGHT HD CONTROL OPTIONS

DMX Input Channel Profiles

DMX Profile	DMX Channels	Channel Assignments	Notes
Studio	6 (Ch. 4 not used)	1 – Intensity 2 – Colour Point (CCT) 3 – Tint 4 – n/a 5 – Strobe 6 – Fan Control	Controls fixture as a white light unit. If no DMX, (console input, for example), is present, the fixture can be adjusted for these three parameters on the user interface at the back of the unit.
Direct	10	1 – Red 2 – Mint 3 – Blue 4 – Indigo 5 – Intensity 6 – Strobe 7 – Fan Control	Direct control of each individual colour with a separate master-intensity channel. Colour calibration of LEDs is not active in this mode. This profile will produce additive colour crossfades.
HSI	6	1 – Hue (coarse) 2 – Hue (fine) 3 – Saturation 4 – Intensity 5 – Strobe 6 – Fan Control	High-resolution hue (two channels), saturation, and intensity control. HSI mode will produce colour crossfades around the colour space.
HSIC	7	1 – Hue (coarse) 2 – Hue (fine) 3 – Saturation 4 – Intensity 5 – Strobe 6 – Fan Control 7 – Color Point (CCT)	High-resolution hue, saturation and intensity control as above, with the addition of a colour- point channel to adjust the colour temperature of the fixture in both white light and color. Colour crossfade performance is the same as HSI.
RGB	6 (Ch. 4 not used)	1 – Red 2 – Green 3 – Blue 4 – n/a 5 – Strobe 6 – Fan Control	Effectively addresses all seven colours via three channels of control. RGB profile will produce additive colour crossfades.

Additional profile options

Plus 7	Seven additional colour-control channels are available in RGB, HSI and HSIC input-profile settings. For example, HSI with 'Plus 7' enabled becomes a 15-channel profile:	
	1 – Intensity 2 – Color Temp 3 – Tint 4 – Strobe 5 – Fan Control 6 – n/a 7 – Plus 7 Control on/off 8 – Red 9 – Mint 10 – Blue 11 – Indigo	The desired colour and intensity is achieved by using the HSI or RGB channels Placing channel seven at a value over 51% gives the fixture a 15-channel profile Channels 9-15 represent the native colours of the fixture and allow the operator to adjust individual colour channels to fine tune the colour output
Strobe	Variable strobe control: 0% is no strobe. The fixture output will strobe more rapidly as the strobe channel value approaches 100%.	

TUNGSTEN HD CONTROL OPTIONS

DMX Input Channel Profiles

DMX Profile	DMX Channels	Channel Assignments	Notes
Studio	6 (Ch. 4 not used)	1 – Intensity 2 – Color Point (CCT) 3 – Tint 4 – n/a 5 – Strobe 6 – Fan Control	Controls fixture as a white light unit. If no DMX, (console input, for example), is present, the fixture can be adjusted for these three parameters on the user interface at the back of the unit.
Direct	10	1 – Red 2 – Red Orange 3 – Mint 4 – Blue 5 – Indigo 6 – Intensity 7 – Strobe 8 – Fan Control	Direct control of each individual colour with a separate master-intensity channel. Colour calibration of LEDs is not active in this mode. This profile will produce additive color crossfades.
HSI	6	1 – Hue (coarse) 2 – Hue (fine) 3 – Saturation 4 – Intensity 5 – Strobe 6 – Fan Control	High-resolution hue (two channels), saturation, and intensity control. HSI mode will produce colour crossfades around the colour space.
HSIC	7	1 – Hue (coarse) 2 – Hue (fine) 3 – Saturation 4 – Intensity 5 – Strobe 6 – Fan Control 7 – Colour Point (CCT)	High-resolution hue, saturation and intensity control as above, with the addition of a colour- point channel to adjust the colour temperature of the fixture in both white light and colour. Colour crossfade performance is the same as HSI.
RGB	6 (Ch. 4 not used)	1 – Red 2 – Green 3 – Blue 4 – n/a 5 – Strobe 6 – Fan Control	Effectively addresses all seven colours via three channels of control. RGB profile will produce additive color crossfades.

Additional profile options

Plus 7	Seven additional color-control channels are available in RGB, HSI and HSIC input-profile settings. For example, HSI with 'Plus 7' enabled becomes a 15-channel profile:	
	1 – Intensity 2 – Colour Temp 3 – Tint 4 – Strobe 5 – Fan Control 6 – n/a 7 – Plus 7 Control on/off 8 – Red 9 – Red Orange 10 – Mint 11 – Blue 12 – Indigo	The desired colour and intensity is achieved by using the HSI or RGB channels Placing channel seven at a value over 51% gives the fixture a 15-channel profile Channels 9-15 represent the native colors of the fixture and allow the operator to adjust individual colour channels to fine tune the colour output
Strobe	Variable strobe control: 0% is no strobe. The fixture output will strobe more rapidly as the strobe channel value approaches 100%.	

PHOTOMETRY

The Source Four LED Photometry Guide and complete IES photometry data files may be downloaded from the ETC website. Go to <http://www.etcconnect.com>

PHYSICAL

Source Four LED Series 2 Weights and Dimensions

	WEIGHT*	SHIPPING WEIGHT
	kgs	kgs
With Barrel	8.3	12.7
Without Barrel	6.5	10.4

* Does not include mounting hardware or lens tube

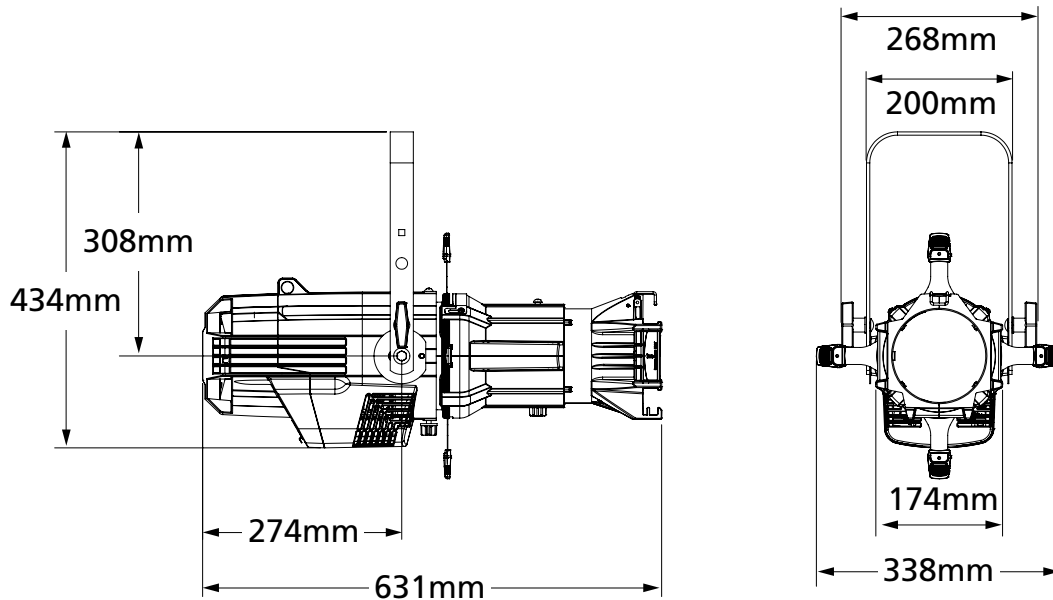

Corporate Headquarters • 3031 Pleasant View Rd, PO Box 620979, Middleton WI 53562 0979 USA • Tel +1 608 831 4116 • Fax +1 608 836 1736
London, UK • Unit 26-28, Victoria Industrial Estate, Victoria Road, London W3 6UU, UK • Tel +44 (0)20 8896 1000 • Fax +44 (0)20 8896 2000
Rome, IT • Via Pieve Torina, 48, 00156 Rome, Italy • Tel +39 (06) 32 111 683 • Fax +44 (0)20 8752 8486
Holzkirchen, DE • Ohmstrasse 3, 83607 Holzkirchen, Germany • Tel +49 (80 24) 47 00-0 • Fax +49 (80 24) 47 00-3 00
Hong Kong • Room 1801, 18/F, Tower 1 Phase 1, Enterprise Square, 9 Sheung Yuet Road, Kowloon Bay, Kowloon, Hong Kong • Tel +852 2799 1220 • Fax +852 2799 9325
Web • www.etcconnect.com • Copyright©2015 ETC. All Rights Reserved. All product information and specifications subject to change. 7461L1000-GB Rev.C 06/2015
 U.S. and international patents pending.